

External Power Supply Installation and DTV Tuner Connections for Engage™ (15" LCD) Consoles with Digital TV Tuner (DVB-T / PAL / FM):

M051-00K88-A004

This document provides information on the new external power supply configurations and DTV Tuner Connections for Engage Consoles with Digital TV Tuner for the following equipment:

- 95T Treadmill
- 95X Cross-Trainer
- 97C and 95C Upright Lifecycle® Exercise Bike
- 95R Recumbent Lifecycle® Exercise Bike

95T Treadmill

Check for External Power

An Engage™ (15" LCD) Console coded "DTV" can receive both analog and digital signals. Life Fitness is not responsible for the installation of TV service or components required for the delivery of TV service. An external TV signal input via a 75-ohm coaxial cable must be present before TV setup can occur.

An Engage Console coded "DTV" is powered by a single 12V DC power supply. "DTV" coded units have a Digital TV Tuner (DVB-T / PAL / FM). **Note:** Engage Consoles coded "ANN & ANP" do not use an external power supply. "ANN & ANP" coded units have an Analog TV Tuner (PAL).

If a Life Fitness Attachable TV is used with the Inspire™ (7" LCD) or Achieve™ Consoles, then a 12V DC power supply is needed for the Attachable TV.

Product Configuration	External Power Supply
Engage Console "DTV"	12V
Engage Console	N/A
Inspire or Achieve Console	N/A
Inspire or Achieve Console with Life Fitness Attachable TV	12V

Note: If the console does not "light up", contact Life Fitness Customer Support Services. Refer to the last page of this document for a contact list.

Recommended Installation of External Power Supply:

- Remove the protective liners from two of the provided fastener strips.
- Attach the fastener strips to the bottom of the 12V power supply.
- Remove the remaining protective liners from fastener strips.
- Secure the power supply to the frame as shown.

Note: The power supply is located under the shroud.

Note to the TV Installer:
 This reminder is provided to call the TV system installer's attention to Article 820-40 of the National Electric Code that provides guidelines for proper grounding and, in particular, specifies that the cable ground shall be connected to the grounding system of the building as close to the point of cable entry as practical.

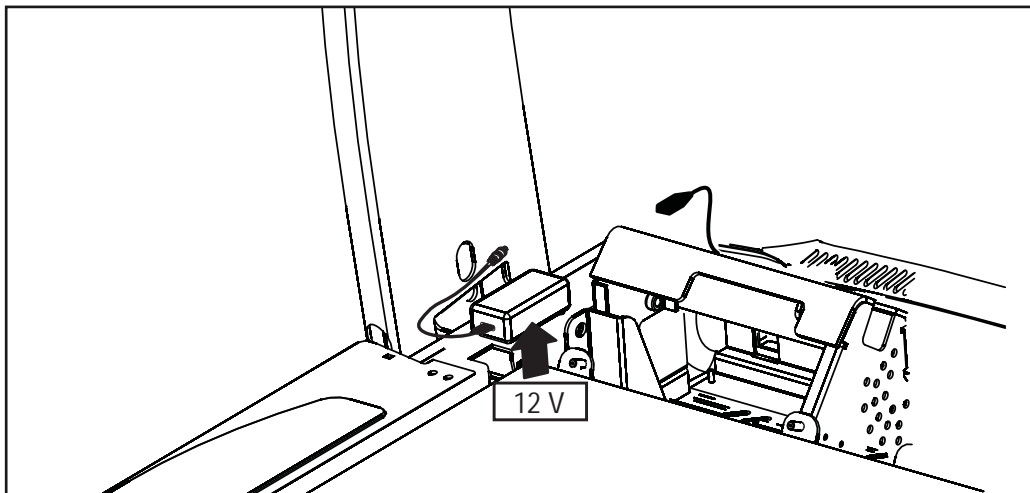

95X Cross-Trainer

Check for External Power

An Engage™ (15" LCD) Console coded "DTC" can receive both analog and digital signals. Life Fitness is not responsible for the installation of TV service or components required for the delivery of TV service. An external TV signal input via a 75-ohm coaxial cable must be present before TV setup can occur.

An Engage Console coded "DTC" is powered by two external power supplies: a 36V / 39V DC power supply and a 12V DC power supply. "DTC" coded units have a Digital TV Tuner (DVB-T / PAL / FM). **Note:** Engage Consoles coded "ANN & ANP" use a single 36V / 39V DC power supply. "ANN & ANP" coded units have an Analog TV Tuner (PAL).

The 36V / 39V power supply is optional for the Inspire™ (7" LCD) and Achieve™ consoles. If a Life Fitness Attachable TV is used with the Inspire or Achieve consoles, then a 12V DC power supply is needed for the Attachable TV.

Product Configuration	External Power Supply
Engage Console "DTC"	12V
Engage Console	36V / 39V
Inspire or Achieve Console	N/A
Inspire or Achieve Console with Life Fitness Attachable TV	12V

Note: If the console does not "light up", contact Life Fitness Customer Services Group. Refer to the last page of this document for a contact list.

Note to the TV Installer:

This reminder is provided to call the TV system installer's attention to Article 820-40 of the National Electric Code that provides guidelines for proper grounding and, in particular, specifies that the cable ground shall be connected to the grounding system of the building as close to the point of cable entry as practical.

Recommended Installation of External Power Supplies:

- Remove the protective liners from two of the provided fastener strips.
- Attach the fastener strips to the bottom of each power supply.
- Remove the remaining protective liners from fastener strips.
- Secure the power supplies to the underside of the center frame as shown.
- Plug connectors to appropriate receptacles.
- Plug Y-Splitter into the appropriate line cord.
- Plug line cord into an AC outlet.

The following connection receptacles are located at the front of the Cross-Trainer:

- 12-V Power for Attachable TV or Engage Console ("DTC")
- Broadcast Supply Input Coaxial Cable
- 36V / 39V External Power
- Fitness Networking



CAUTION: Connectors should easily fit into the receptacles. Forcing a connection may lead to damage to the barrel connector and/or receptacle and may void product warranty.

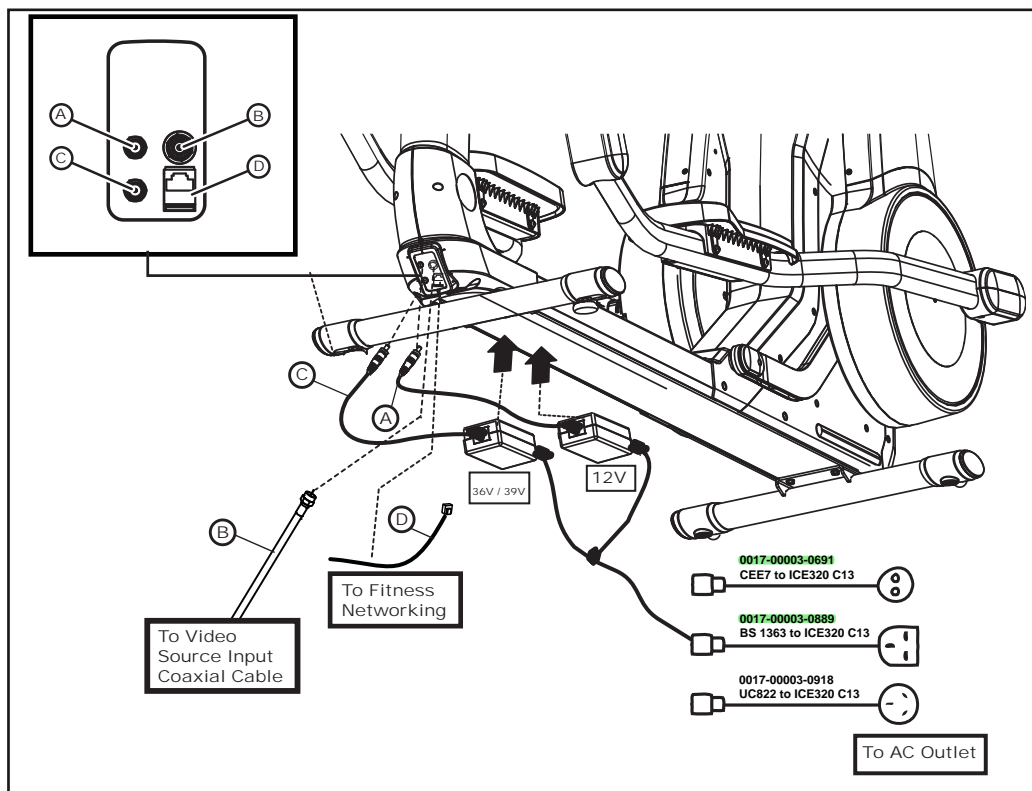

95R Recumbent Lifecycle® Exercise Bike

Check for External Power

An Engage™ (15" LCD) Console coded "DTC" can receive both analog and digital signals. Life Fitness is not responsible for the installation of TV service or components required for the delivery of TV service. An external TV signal input via a 75-ohm coaxial cable must be present before TV setup can occur.

An Engage Console coded "DTC" is powered by two external power supplies: a 36V / 39V DC power supply and a 12V DC power supply. "DTC" coded units have a Digital TV Tuner (DVB-T / PAL / FM). **Note:** Engage Consoles coded "ANN & ANP" use a single 36V / 39V DC power supply. "ANN & ANP" coded units have an Analog TV Tuner (PAL).

The 36V / 39V power supply is optional for the Inspire™ (7" LCD) and Achieve™ Consoles. If a Life Fitness Attachable TV is used with the Inspire or Achieve Consoles, then a 12V DC power supply is needed for the Attachable TV.

Product Configuration	External Power Supply
Engage Console "DTC"	12V
Engage Console	36V / 39V
Inspire or Achieve Console	N/A
Inspire or Achieve Console with Life Fitness Attachable TV	12 V

Note: For external powered units, the console should immediately beep and "light up". The Engage console will show a message indicating it is initializing (for up to 2 minutes). If any of the consoles do not "light up", contact Life Fitness Customer Services Group. Refer to the last page of this document for a contact list.

Note to the TV Installer:

This reminder is provided to call the TV system installer's attention to Article 820-40 of the National Electric Code that provides guidelines for proper grounding and, in particular, specifies that the cable ground shall be connected to the grounding system of the building as close to the point of cable entry as practical.

Recommended Installation of External Power Supplies:

- Remove the protective liners from two of the provided fastener strips.
- Attach the fastener strips to the bottom of each power supply.
- Remove the remaining protective liners from fastener strips.
- Secure the power supplies to the underside of the center frame as shown.
- Plug connectors to appropriate receptacles.
- Plug Y-Splitter into the appropriate line cord.
- Plug line cord into an AC outlet.

The following connection receptacles are located at the front of the Recumbent Lifecycle Exercise Bike:

- | | |
|---|-----------------------------|
| A. 12-V Power for Attachable TV or Engage Console ("DTC") | C. 36V / 39V External Power |
| B. Broadcast Supply Input Coaxial Cable | D. Fitness Networking |

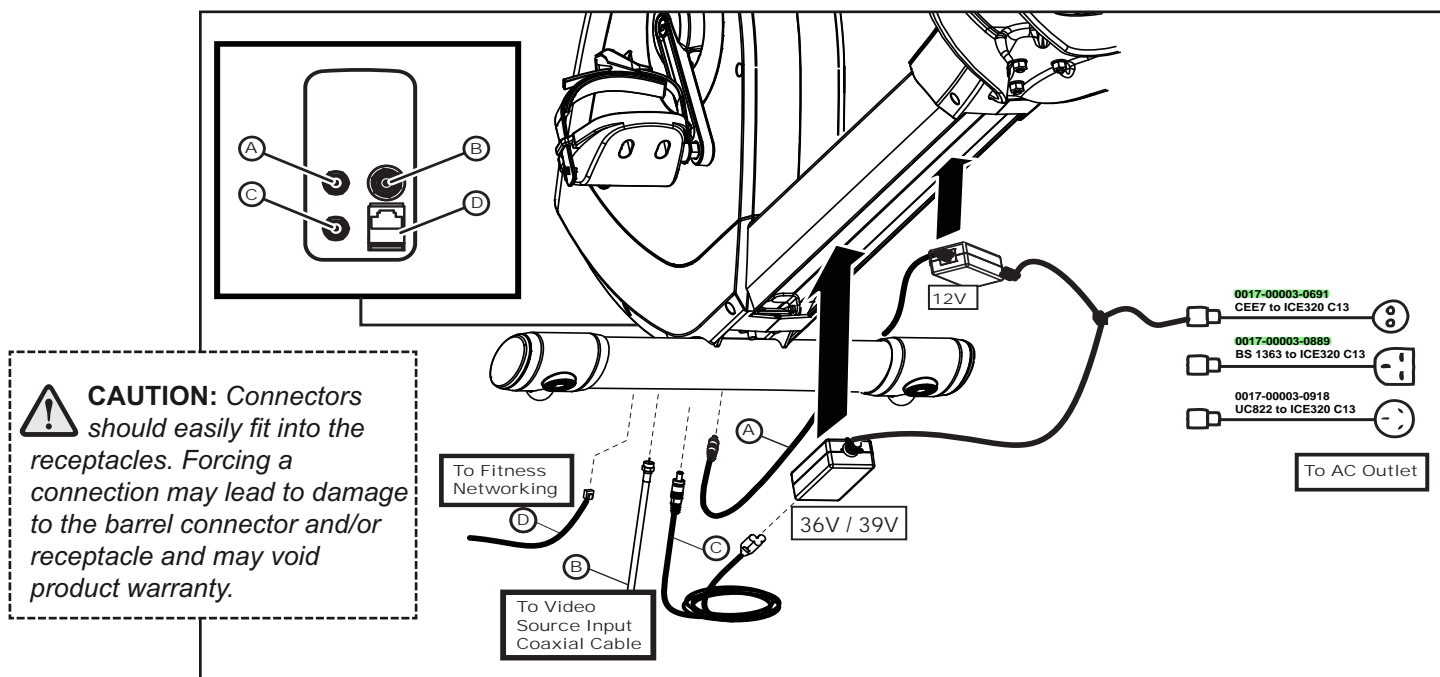

97C, 95C Upright Lifecycle® Exercise Bike

Check for External Power

An Engage™ (15" LCD) Console coded "DTC" can receive both analog and digital signals. Life Fitness is not responsible for the installation of TV service or components required for the delivery of TV service. An external TV signal input via a 75-ohm coaxial cable must be present before TV setup can occur.

An Engage Console coded "DTC" is powered by two external power supplies: a 36V / 39V DC power supply and a 12V DC power supply. "DTC" coded units have a Digital TV Tuner (DVB-T / PAL / FM). **Note:** Engage Consoles coded "ANN & ANP" use a single 36V / 39V DC power supply. "ANN & ANP" coded units have an Analog TV Tuner (PAL).

The 36V / 39V power supply is optional for the Inspire™ (7" LCD) and Achieve™ consoles. If a Life Fitness Attachable TV is used with the Inspire or Achieve consoles, then a 12V DC power supply is needed for the Attachable TV.

Product Configuration	External Power Supply
Engage Console "DTC"	12V
Engage Console	36V / 39V
Inspire or Achieve Console	N/A
Inspire or Achieve Console with Life Fitness Attachable TV	12V

Note: For external powered units, the console should immediately beep and "light up". The Engage console will show a message indicating it is initializing (for up to 2 minutes). If the console does not "light up", contact Life Fitness Customer Services Group. Refer to the last page of this document for a contact list.

Note to the TV Installer:

This reminder is provided to call the TV system installer's attention to Article 820-40 of the National Electric Code that provides guidelines for proper grounding and, in particular, specifies that the cable ground shall be connected to the grounding system of the building as close to the point of cable entry as practical.

Recommended Installation of External Power Supplies:

- Piggyback both external power supplies using the included cable ties.
- Remove the protective liner from one of the provided fastener strips.
- Attach the fastener strips to the bottom of one of the power supplies.
- Remove the remaining protective liner from fastener strip.
- Secure the piggybacked power supplies to the underside of the center frame as shown.
- Plug connectors to appropriate receptacles.
- Plug Y-Splitter into the appropriate line cord.
- Plug line cord into an AC outlet.

The following connection receptacles are located at the front of the Upright Lifecycle Exercise Bike:

- 12-V Power for Attachable TV or Engage Console ("DTC")
- Broadcast Supply Input Coaxial Cable
- 36V / 39V External Power
- Fitness Networking



CAUTION: Connectors should easily fit into the receptacles. Forcing a connection may lead to damage to the barrel connector and/or receptacle and may void product warranty.

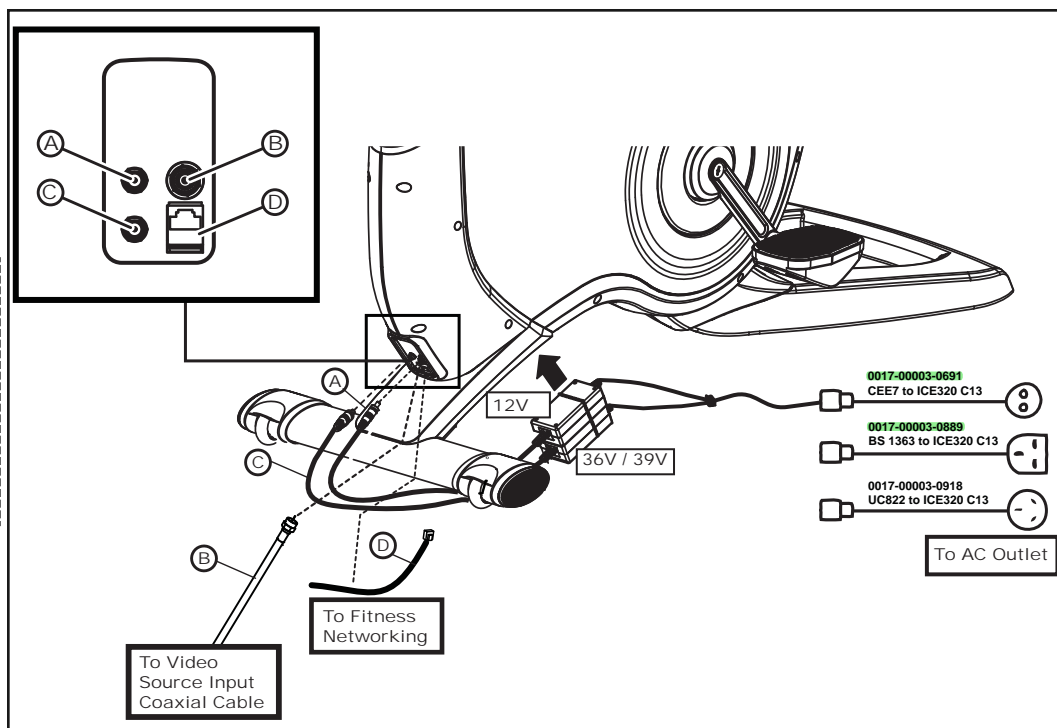

Engage Console with Digital TV Tuner Board

An accessory box is included with the Digital TV Tuner Engage console packaging. Contents includes:

Treadmills	Bikes and Cross-Trainers
12V Power Supply Dual Lock Fastener Strips Cable Ties	12V Power Supply 36V / 39V Power Supply Y-Splitter Dual Lock Fastener Strips Cable Ties CEE7 Line Cord BS1363 Line Cord UC822 Line Cord

The DTV Tuner Board includes the DTV Tuner and the Power for the DTV Tuner. Connections are shown below.

Note: The previous analog-only console did not require a 12V power supply.

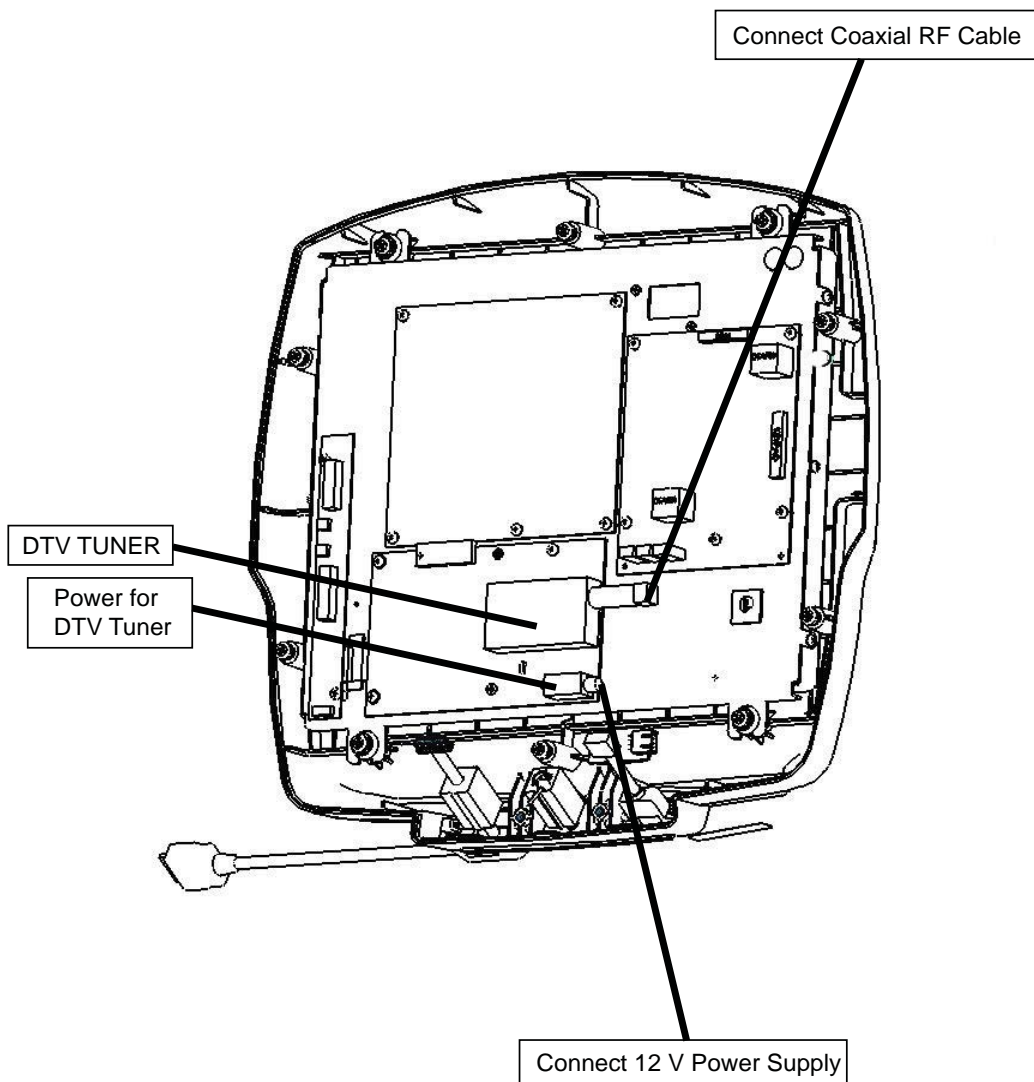

Cable Connections

The Analog TV Tuner (PAL) has an “L” shaped coaxial cable connector that is moveable and attachable. The Digital TV Tuner (DVB-T / PAL / FM) has a fixed coaxial cable connector.

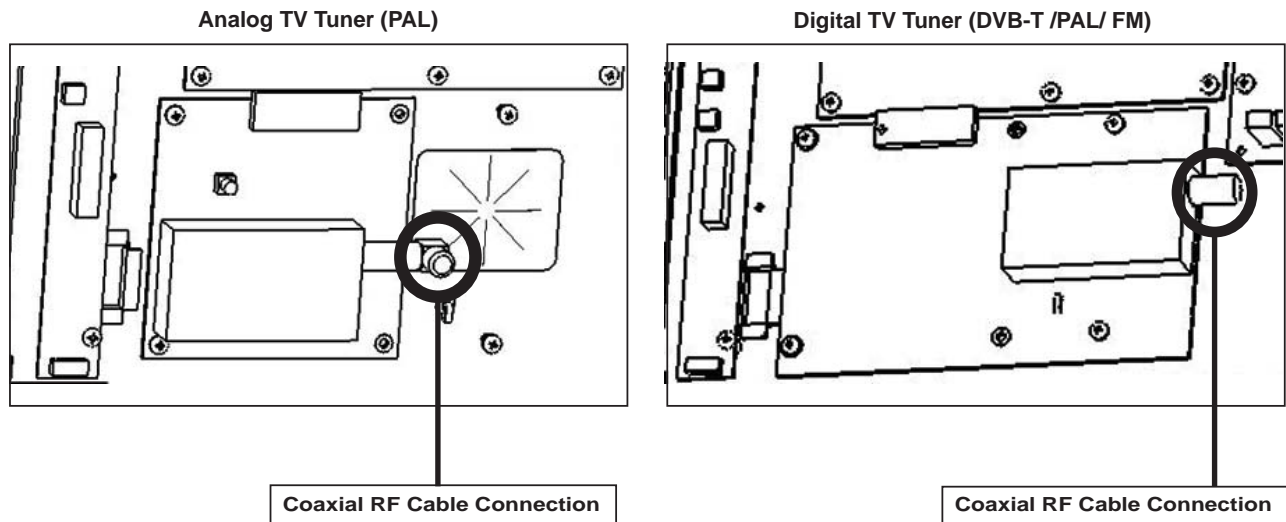

Note: If a Life Fitness Attachable TV is used with the Inspire™ or Achieve™ consoles, then the 12V Power Supply connects to the corresponding receptacle on the back of the TV.

CORPORATE HEADQUARTERS

5100 River Road
Schiller Park, Illinois 60176 • U.S.A.
847.288.3300 • FAX: 847.288.3703
800.735.3867 (Toll-free within U.S.A., Canada)
Global Website: www.lifefitness.com

INTERNATIONAL OFFICES

AMERICAS

North America Life Fitness Inc.

5100 N River Road
Schiller Park, IL 60176 U.S.A
Telephone: (847) 288 3300
Fax: (847) 288 3703
Service Email: customersupport@lifefitness.com
Sales/Marketing Email: commercialsales@lifefitness.com
Operating Hours: 7:00 am-6:00 pm (CST)

Brazil Life Fitness Brasil

Av. Cidade Jardim, 900
Jd. Paulistano
São Paulo, SP 01454-000
BRAZIL
SAC: 0800 773 8282
Telephone: +55 (11) 3095 5200
Fax: +55 (11) 3095 5201
Service Email: suporte@lifefitness.com.br
Sales/Marketing Email: lifefitness@lifefitness.com.br
Service Operating Hours:
9:00 - 17:00 (BRT) (Monday-Friday)
Store Operating Hours:
9:00 -20:00 (BRT) (Monday-Friday)
10:00 - 16:00 (BRT) (Saturday)

Latin America & Caribbean* Life Fitness Inc.

5100 N River Road
Schiller Park, IL 60176 U.S.A
Telephone: (847) 288 3300
Fax: (847) 288 3703
Service Email: customersupport@lifefitness.com
Sales/Marketing Email: commercialsales@lifefitness.com
Operating Hours: 7:00am-6:00pm (CST)

EUROPE, MIDDLE EAST, & AFRICA (EMEA)

Netherlands & Luxembourg Life Fitness Atlantic BV

Bijdorplein 25-31
2992 LB Barendrecht
THE NETHERLANDS
Telephone: (+31) 180 646 666
Fax: (+31) 180 646 699
Service Email: service.benelux@lifefitness.com
Sales/Marketing Email:
marketing.benelux@lifefitness.com
Operating Hours: 9.00h-17.00h (CET)

United Kingdom & Ireland Life Fitness UK LTD

Queen Adelaide
Ely, Cambs, CB7 4UB
Telephone: General Office (+44) 1353.666017
Customer Support (+44) 1353.665507
Fax: (+44) 1353.666018
Service Email: uk.support@lifefitness.com
Sales/Marketing Email: life@lifefitness.com
Operating Hours:
General Office: 9.00am - 5.00pm (GMT)
Customer Support: 8.30am - 5.00pm (GMT)

Germany & Switzerland Life Fitness Europe GMBH

Siemensstraße 3
85716 Unterschleißheim
GERMANY
Telephone: (+49) 89.31 77 51.0 (Germany)
(+41) 0848 000 901 (Switzerland)
Fax: (+49) 89.31 77 51.99 (Germany)
(+41) 043 818 07 20 (Switzerland)
Service Email: kundendienst@lifefitness.com
Sales/Marketing Email: kundenberatung@lifefitness.com
Operating Hours: 08.30 - 16.30h (CET)

Austria Life Fitness Austria

Vertriebs G.m.b.H.
Dückerstraße 7-9/3/36
1220 Vienna
AUSTRIA
Telephone: (+43) 1.61.57.198
Fax: (+43) 1.61.57.198.20
Service Email: kundendienst@lifefitness.com
Marketing/Sales Email: kundenberatung@lifefitness.com
Operating Hours: 9.00h-17.00h (MEZ)

Spain Life Fitness IBERIA

C/Frederic Mompou 5,1ª^a
08960 Sant Just Desvern Barcelona
SPAIN
Telephone: (+34) 93.672.4660
Fax: (+34) 93.672.4670
Service Email: info.iberia@lifefitness.com
Sales/Marketing Email: info.iberia@lifefitness.com
Operating Hours:
9.00h-18.00h (Monday-Thursday)
8.30h-15.00h (Friday)

Belgium Life Fitness Benelux NV

Parc Industriel de Petit-Rechain
4800 Verviers
BELGIUM
Telephone: (+32) 87 300 942
Fax: (+32) 87 300 943
Service Email: internationalservicesupport@lifefitness.com
Sales/Marketing Email: marketing.benelux@lifefitness.com
Operating Hours: 9.00h -17.00h (CET)

Italy Life Fitness Europe GmbH

Siemensstraße 3
85716 Unterschleißheim
GERMANY
Telephone: (+39) 02-55378611
Service: 800438836 (In Italy)
Fax: (+39) 02-55378699
Service Email: assistenza@lifefitness.com
Sales/Marketing Email: info@lifefitnessitalia.com
Operating Hours: 08:30 - 16:30h (CET)

All Other EMEA countries & distributor business C-EMEA*

Bijdorplein 25-31
2992 LB Barendrecht
THE NETHERLANDS
Telephone: (+31) 180 646 644
Fax: (+31) 180 646 699
Service Email: service.db.cemea@lifefitness.com
Sales/Marketing Email:
marketing.db.cemea@lifefitness.com
Operating Hours: 9.00h-17.00h (CET)

ASIA PACIFIC (AP)

Japan Life Fitness Japan

Nippon Brunswick Bldg., #8F
5-27-7 Sendagaya
Shibuya-Ku, Tokyo
Japan 151-0051
Telephone: (+81) 3.3359.4309
Fax: (+81) 3.3359.4307
Service Email: service@lifefitnessjapan.com
Sales/Marketing Email: sales@lifefitnessjapan.com
Operating Hours: 9.00h-17.00h (JAPAN)

China and Hong Kong Life Fitness Asia Pacific LTD

Room 2610, Miramar Tower
132 Nathan Road
Tsimshatsui, Kowloon
HONG KONG
Telephone: (+852) 2891.6677
Fax: (+852) 2575.6001
Service Email: HongKongEnquiry@lifefitness.com
Sales/Marketing Email: ChinaEnquiry@lifefitness.com
Operating Hours: 9.00h-18.00h

All Other Asia Pacific countries & distributor business Asia Pacific*

Room 2610, Miramar Tower
132 Nathan Road
Tsimshatsui, Kowloon
HONG KONG
Telephone: (+852) 2891.6677
Fax: (+852) 2575.6001
Service Email: HongKongEnquiry@lifefitness.com
Sales/Marketing Email: ChinaEnquiry@lifefitness.com
Operating Hours: 9.00h-18.00h